

1 2 3 4 5

D

D

C

C

B

B

A

A

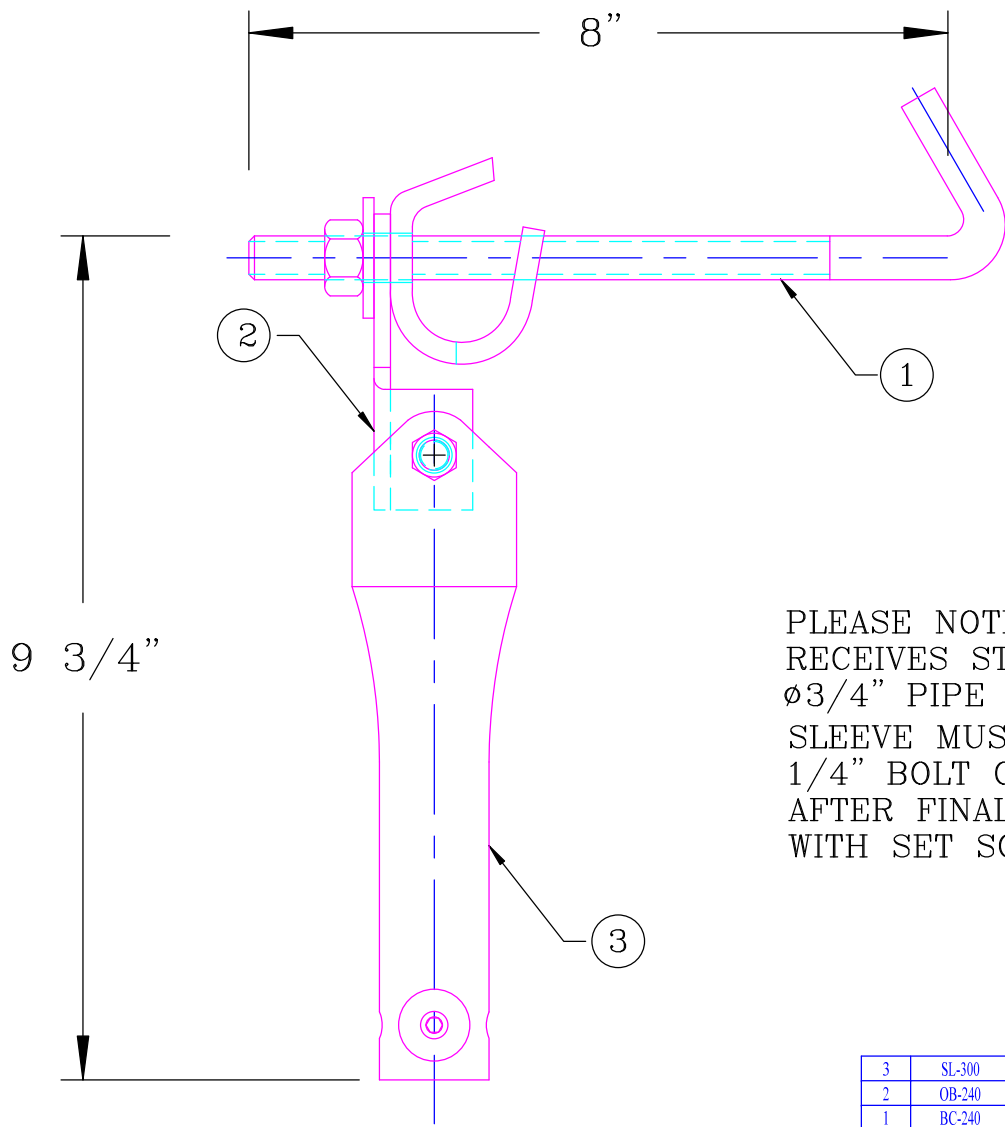

PLEASE NOTE:
 RECEIVES STD. SCH.40,
 $\phi 3/4$ " PIPE (1.05"O.D.)
 SLEEVE MUST BE BOLTED WITH
 1/4" BOLT OR TEK SCREWED
 AFTER FINAL ADJUSTMENT
 WITH SET SCREW.

3	SL-300	TRACK HANGER SLEEVE	1
2	OB-240	OFFSET BRACKET (for Beam Clamp)	1
1	BC-240	BEAM CLAMP	1
ITEM	PART NO.	DESCRIPTION	QUANTITY

BRIDGEVEYOR OVERHEAD SYSTEMS LTD

www.bridgeveyor.com

A	02/06/03	INITIAL RELEASE	AB
REV	DATE	DESCRIPTION	REV'D BY
This document contains information proprietary to Bridgeveyor Systems and no part of this drawing shall be reproduced or disclosed to others or used for any purpose other than that for which it was furnished without prior written permission from Bridgeveyor.			

DRAWN BY	R.G.	DRAWING NAME:	BEAM CLAMP c/w 6 1/2" SILVER SLEEVE
DATE	JANUARY, 2003	PART NUMBER:	BC-300
APPR'D BY		DRAWING NUMBER:	
SCALE	NTS	REV	

DRAWING FOR CONCEPT PURPOSES ONLY
 DIMENSIONS MAY VARY

1 2 3 4 5